

# Metering Technology



## DOPAG Material pressure regulators (MPR)



Hilger u. Kern / Dopag Group

# **Material pressure regulators for a reduced and continuous material pressure for all metering and dispensing applications**

## **Perfect pressure ratio**

### **Material pressure regulators**

DOPAG material pressure regulators are used to reduce the feed pressure down to the required operating pressure.

As well as accurately regulating material pressure, these valves will also compensate for pulsations that occur as a result of the reciprocating action of piston pumps.

Pulsations cause a brief decrease in pressure that could lead to a slight reduction in the flow of material.

These regulators can be used on materials with viscosities from 5,000 to 500,000 mPa s.

DOPAG material pressure regulators are manufactured with two different types of construction:

- **Regulators with piston**
- **Regulators with membrane**

Optionally, a remote control is available for valves with membrane to regulate the operating pressure in place of manual adjustment.

Optionally, twin pressure gauges display the material input pressure as well as the material outlet pressure.

Optionally, material input filters are available to prevent contamination and possible blockages within the system.

**1K system concept**

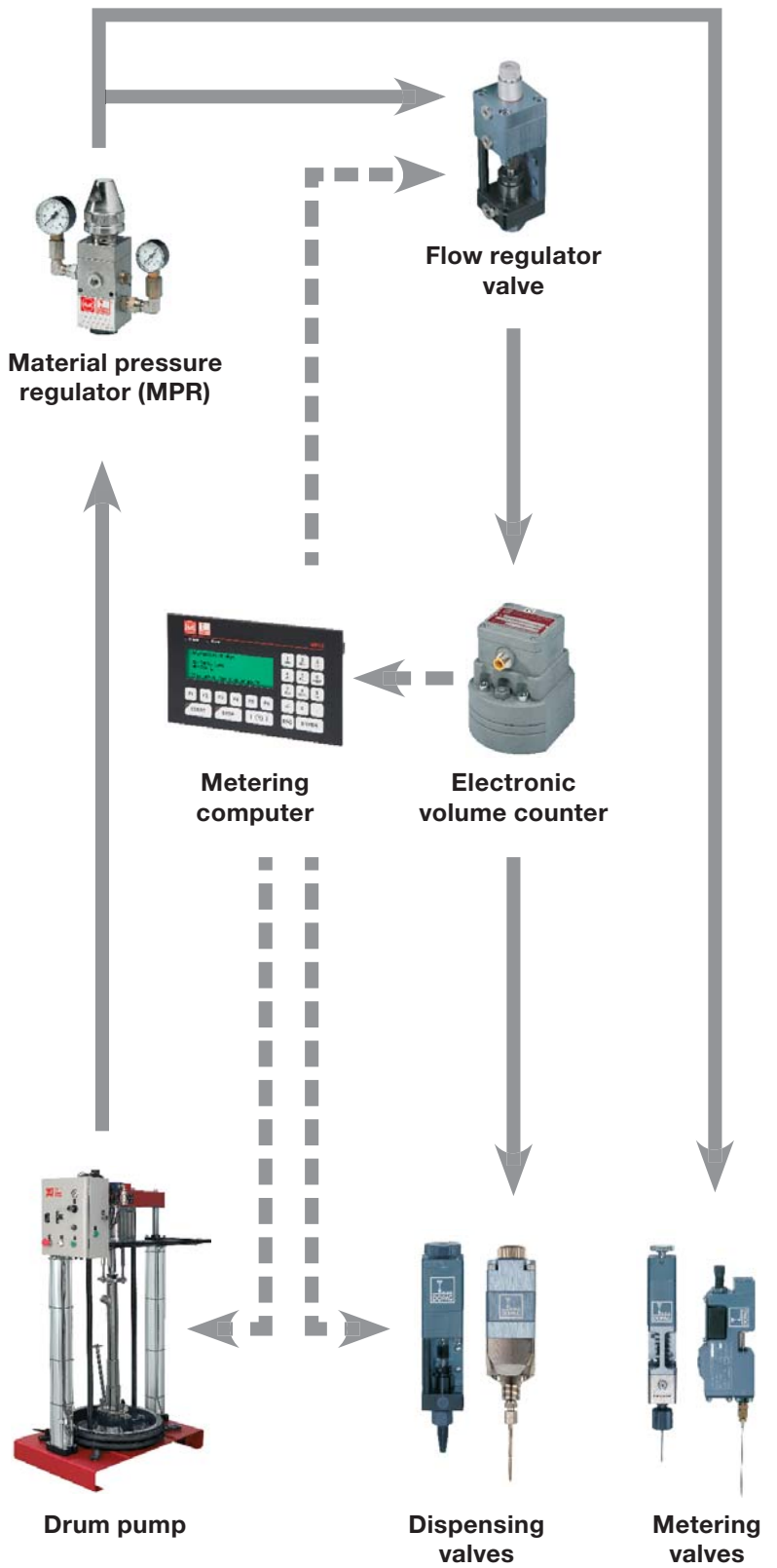

## MPR with piston

This type of material pressure regulator is especially suitable for the processing of self-lubricating materials such as greases and oils as well as single and plural component silicones.

The sealing of the spring space takes place via a slide ring seal.

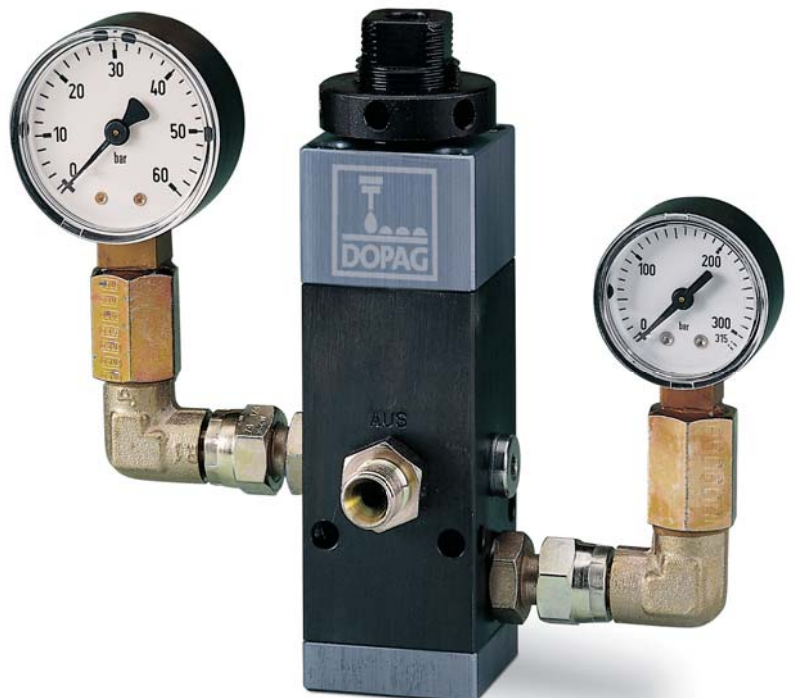
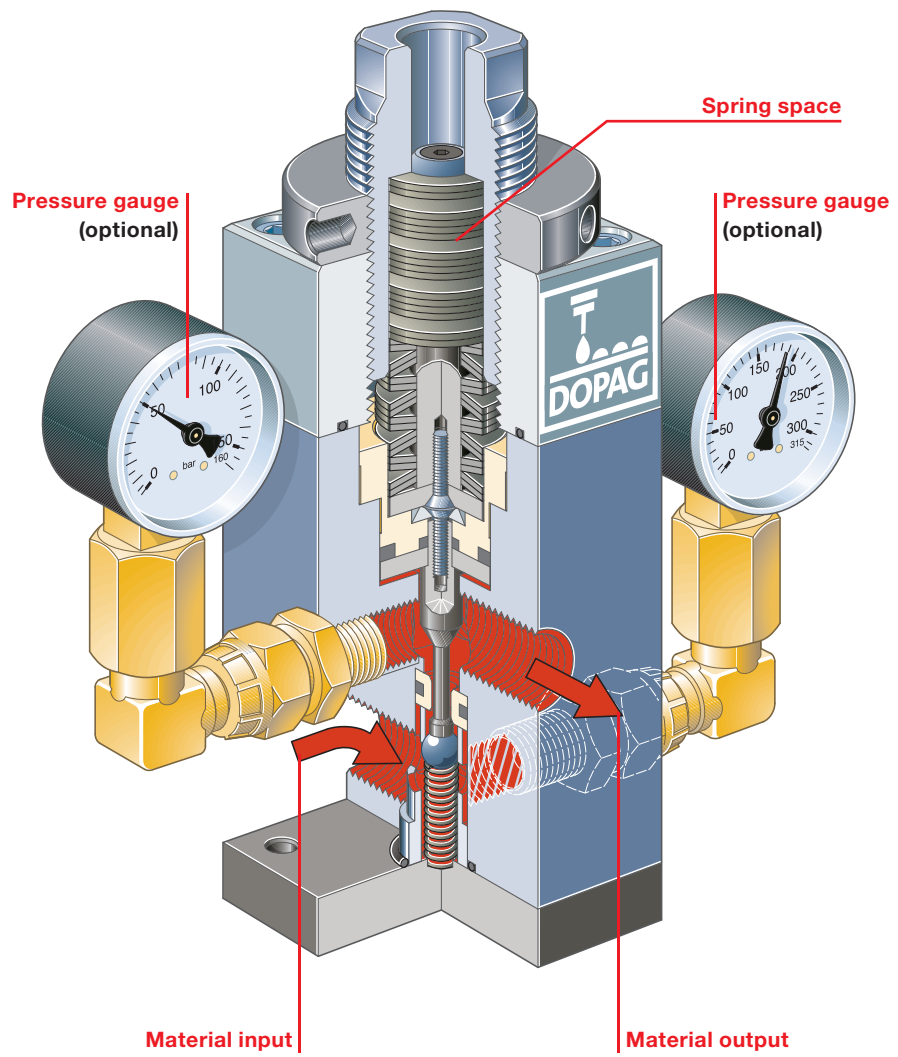

## MPR with membrane

This type of material pressure regulator is most suitable for use with reactive, moisture sensitive and, because the ball and seat are manufactured from tungsten carbide, also abrasive media, such as, epoxy resins, polyurethanes and many other materials.

The sealing of the spring space takes place via the membrane.

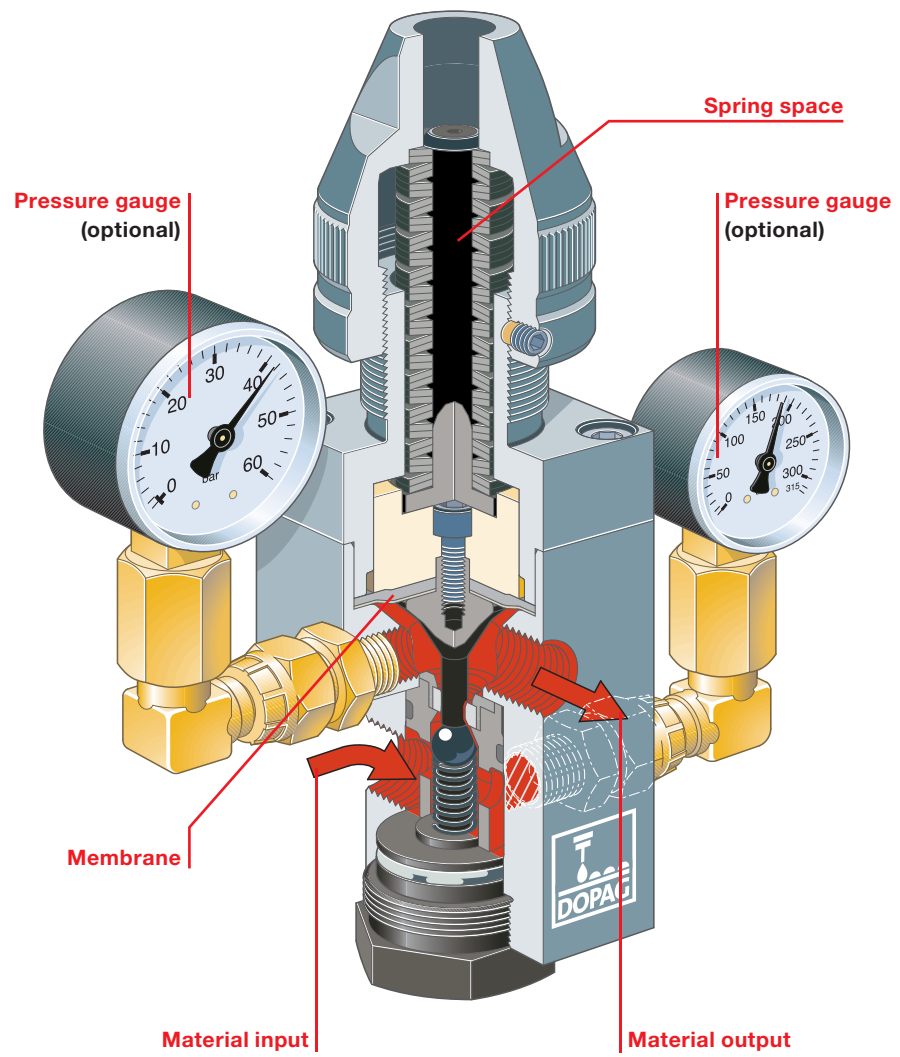



## Remote control for MPR with membrane

The remote control enables easy and accurate setting of the operating pressure, without any manual adjustment, to respond to changing production conditions or flow rates.

The change in operating pressure occurs as a result of the adjustment of the air pressure to the membrane.

This is especially useful when regulators are located in difficult to access or hard to reach areas.

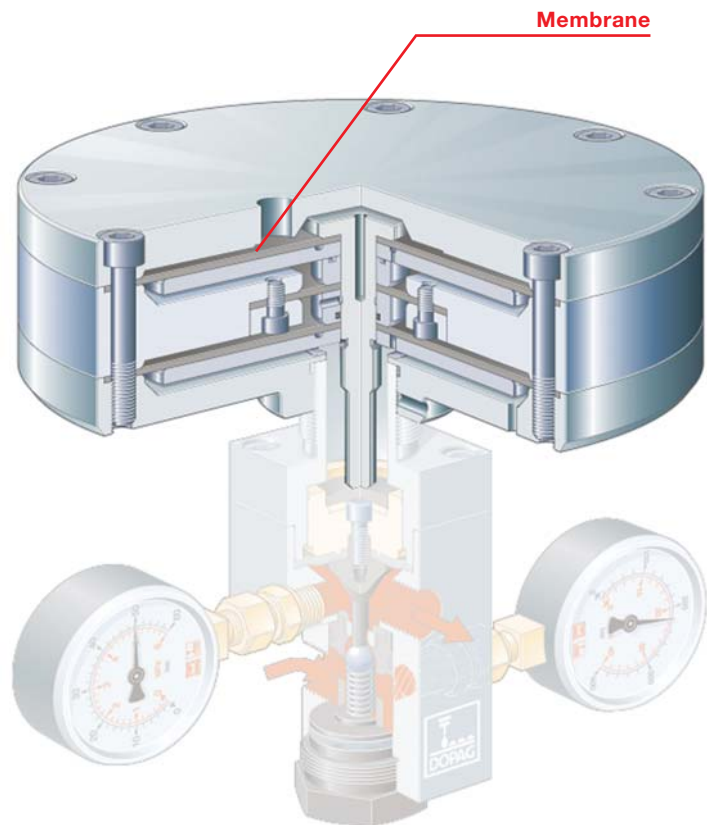

# Technical data



## Material pressure regulator with piston

Part no.		400.25.93 (1)	400.25.94 (1)	400.25.92 (1)	400.25.91 (1)	400.25.95 (2)	402.25.80* (3)
Input pressure max.	bar	250	400	250	250	250	300
Output pressure max.	bar	50	150	50	50	150	150
Internal diameter Ø	mm	4	4	8	12	12	12
Connection	G	1/4	3/8	3/8	1/2	1/2	1/2
Dimensions	mm	40 x 40	60 x 60	60 x 60	60 x 60	60 x 60	SW 50/55
Height max.	mm	150	190	190	190	190	200
Weight	kg	1,20	3,30	3,10	3,00	3,00	3,20
Ball seat		hardened steel	hardened steel	hardened steel	hardened steel	hardened steel	hardened steel

Possibilities to use material input filters (400.25.XX): (1) already integrated, (2) possible as an option, (3) not possible

\* Special material pressure regulator for two component silicones



## Material pressure regulator with membrane

Part no.		402.25.20 (2)	402.25.40 (2)	402.25.00 (2)	402.25.50 (2)	402.25.60 (2)	402.25.30 (2)
Input pressure max.	bar	250	250	250	250	250	250
Output pressure max.	bar	50	150	50	150	50	150
Internal diameter Ø	mm	4	4	8	8	12	12
Connection	G	3/8	3/8	3/8	3/8	1/2	1/2
Dimensions	mm	55 x 55	55 x 55	55 x 55	55 x 55	65 x 65	65 x 65
Height max.	mm	210	210	210	210	210	210
Weight	kg	3,30	3,30	3,30	3,30	4,50	4,50
Ball seat		tungsten carbide	tungsten carbide	tungsten carbide	tungsten carbide	tungsten carbide	tungsten carbide

Possibilities to use material input filter (402.25.XX): (2) possible as an option



## Remotely controlled material pressure regulator with membrane

Part no.		402.26.41 *	402.26.01 *	402.26.31 *
Input pressure max.	bar	250	250	250
Output pressure max.	bar	150	150	150
Internal diameter Ø	mm	4	8	12
Pneumatic pressure	bar	0-6	0-6	0-6
Dimensions Ø	mm	200	200	200
Height max.	mm	210	210	243
Weight	kg	8,60	8,60	11,00

\* All further technical data is identical to the material pressure regulator with membrane data

# Hilger u. Kern / Dopag Group

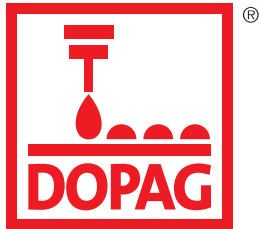

The Hilger u. Kern / Dopag Group, with more than 250 employees, is one of the leading manufacturers of metering and mixing systems in the world for plural component polymers and single component media such as greases, oils and pastes.

## Germany

Hilger u. Kern GmbH  
Industrietechnik  
Käfertaler Straße 253  
68167 Mannheim

☎ +49 621 3705-0  
📠 +49 621 3705-200  
info@hilger-kern.de  
www.hilger-kern.com

## Switzerland

DOPAG Dosiertechnik  
und Pneumatik AG  
Langackerstrasse 25  
6330 Cham

☎ +41 41 7855-757  
📠 +41 41 7855-700  
info@dopag.ch  
www.dopag.com

For more than 35 years the group, with subsidiaries and distributors in over 30 countries, has developed systems and components to suit your individual needs.

## Subsidiaries

### France

DOPAG Sarl  
contact@dopag.fr

### China

Hilger u. Kern Trading Co., Ltd.  
office@hilger-kern.cn

### Italy

DOPAG ITALIA S.r.l.  
info.it@dopag.com

### Malaysia

DOPAG FAR EAST SDN BHD  
info@dopag.com.my

### United Kingdom

DOPAG (UK) Ltd.  
uksales@dopag.co.uk

### USA

DOPAG (US) Ltd.  
ussales@dopag.com

Please visit our internet page to find the contact data of your local partner (Sales and Service Organisation).